

# Digital Manufacturing Process



## Guide to quality STL files

RedEye On Demand  
8081 Wallace Road  
Eden Prairie, MN 55344

phone: 952-906-2725  
toll free: 866-882-6937  
email: [godigital@redeyeondemand.com](mailto:godigital@redeyeondemand.com)

[www.redeyeondemand.com](http://www.redeyeondemand.com)

# Guide to Quality STL Files

## Introduction

If you've ever ordered a prototype or production part online, your part may have looked different than you expected. Why? Because sometimes data is lost when you convert your file from CAD to STL.

Since nearly every rapid prototyping and digital manufacturing (end-use parts) organization uses STL files to build parts, it is important to understand what STL is and what settings you can adjust to get the part you really want.

[What is an STL file?](#)

[How can I make sure I get the part I want?](#)

[Seven key shape optimization settings](#)

[Angle, Deviation & Chord Height \(faceting /smoothness\)](#)

[Wall Thickness \(unexpected holes, gaps, flimsy areas\)](#)

[Multiple Shells or Nested Parts](#)

[Tabbed Parts](#)

[Inversed Normals](#)

[Edges](#)

[Surfaces](#)

[Conclusion](#)

[About RedEye On Demand](#)

## What is an STL file?

Simply explained, a STL file is a format used by popular prototyping and digital manufacturing software to generate information needed to produce 3D models. The STL format approximates the surfaces of a solid, surface or scanned model with triangles.

For a simple model, such as the box shown in figure 1, its surfaces can be approximated with twelve triangles, two on each side, as shown in figure 2. The more complex the surface, the more triangles produced as shown in figure 3.



Figure 1



Figure 2



Figure 3

Almost all of today's CAD systems are capable of producing an STL file. In fact, the process is often as simple as selecting File, Save As and STL. We have done our best to combine easy step-by-step directions for saving STL files for many software manufacturers – download your copy of [Saving Your CAD as STL](#). Because software continually evolves, we cannot guarantee this information is up-to-date with the version you are using. If you do not find the information you need, please contact your software representative.

# How can I make sure I get the part I want?

There is an easy way to ensure that what you see is actually what you'll get. Simply adjust 7 key settings before you start file conversion: angle, deviation & chord height, wall thickness, multiple shells, nested or tabbed areas, surfaces, inversed normals and edges.

Unfortunately, most CAD programs do not allow you to view your final STL file, so you will likely have to install one separately. All viewing tools provide visual information, but some also provide you with visual information on where areas of concern are within your native file.

Download RedEye's free proprietary STL viewer:

[Discover.STL](#)

## Seven Key Shape Optimization Settings

These 7 settings determine the way your parts will look when produced.

- angle, deviation & chord height
- wall thickness
- multiple shells or nested parts
- tabbed areas
- surfaces
- Inversed normals
- edges

Adjusting these critical settings before file conversion is important because STL files cannot be edited, changed or made smoother after they are uploaded to a prototyping or digital manufacturing agency.

### Angle, Deviation & Chord Height (Faceting & Smoothness)

If your part was rougher or smoother than you had hoped, you can change the angle, deviation and chord height to create the right outcome. Faceting is determined by the relative coarseness of curved areas of the adjoining triangles. The most common variables are deviation or chord height, and angle control or angle tolerance.

Following are three examples of various STL faceting outputs determined by varying angle, deviation and chord height: Coarse faceting (poor), excessive fine faceting (fair) and good quality faceting (best).

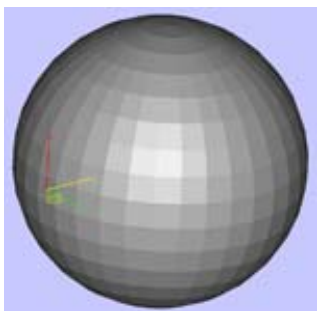

File Size: 705KB

**Coarse Faceting (poor):** When the faceting is too coarse you can see flat spots on curved surfaces. The flat spots in the .stl file will show up when the part is produced. Coarse faceting is almost always caused by the angle setting being too high, or the deviation/chord height settings being too large, or a combination of both.

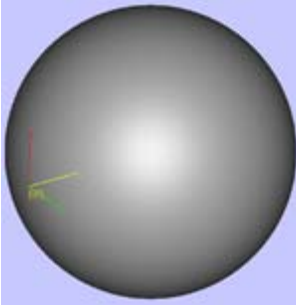

File Size: 17,350KB

**Excessively Fine Faceting (fair):** Fine faceting can cause delays in processing and uploading of parts because of the larger size. Increasing the resolution excessively does not necessarily improve the quality of the produced part. This is caused by the angle settings being too low, or the deviation/chord height settings being too small, or a combination of both.

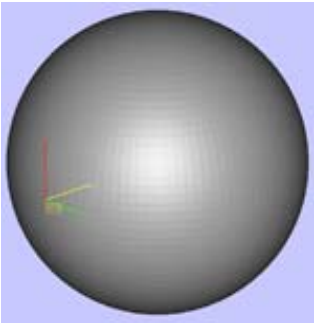

File Size: 2,760KB

**Good Quality Faceting (best):** The happy medium between the two extremes is good quality faceting, just detailed enough so that features build to the file dimensions, while being simple enough to maintain a manageable file size.

Note: The faceting you see in these images is exactly what will be built.

## Wall Thickness

Sometimes wider is better, especially if you've ordered a prototype only to be met with unexpected holes, gaps, missing pieces or flimsy walls. As an easy way to make sure what you see is what you get, measure wall thickness before having a prototype made.

For example: the thinnest wall, using standard slice resolution, that can be built using Fused Deposition Modeling™ (FDM) technology is 0.04 inches (1.016mm). See what might happen if the walls are too thin by reviewing the drawing on the following page. Also, it's important to look for areas that converge into each other where walls get pinched.

## Drawing Showing Wall Thickness

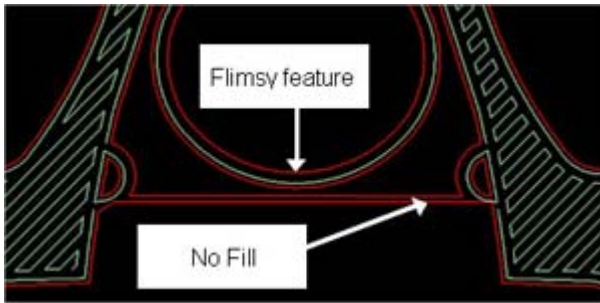

In the above image, red indicates the slice curve or cross-section of the STL file and green is the tool path. One of the walls is so thin that a tool path is not calculated. In the other thin region a tool path can be calculated; however, it's important to note that the outcome will be a flimsy or fragile region. In addition, this pinched area may be built as a hole in the part.

If you use photopolymer (PolyJet™) technology, you can create parts with thinner features. Most thin walls will build, but may be somewhat fragile and are susceptible to damage during support removal, testing and handling.

## Multiple Shells, Nested or Tabbed Parts

Getting prototypes or production parts of assemblies, multiple shells or parts nested together can be even trickier. To ensure accurate quoting and quick delivery for these types of parts, you should always save each individual piece as a separate STL file. If files are not separated, they often appear as one part which slows the production process costing you time and money.

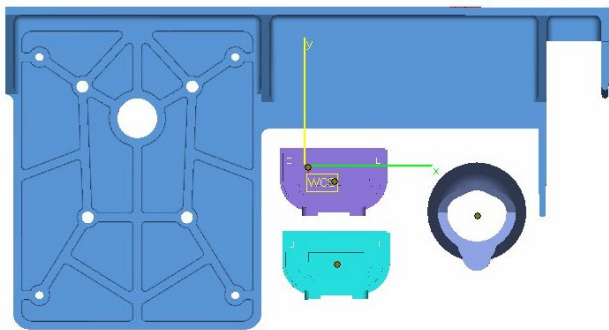

Example of a file with Multiple Parts

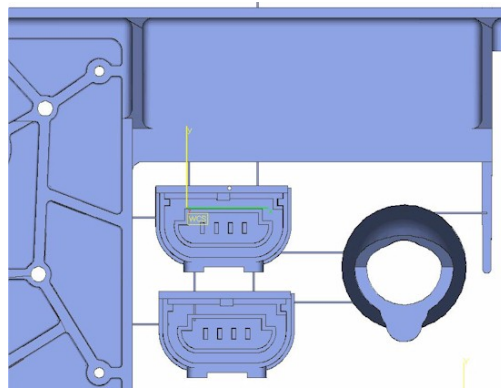

Example of a file with Nested Parts

Many agencies will not produce tabbed parts because the break away walls are too thin. An example of a tabbed part is a model airplane kit. Each individual part is connected together by tabs that when twisted remove individual components.

It is always best to send files as independent parts and follow-up with your preferred vendor before placing your order.

## Inversed Normals, Edges and Surfaces

Often, clean STL files are referred to as being "water-tight". This means that there are no missing surfaces, surfaces that overlap, inversed normals or bad edges.

Typically most "solids modeling" CAD applications such as SolidWorks, Inventor or ProE, produce clean water-tight files consistently. CAD applications based on "surfaces", such as Rhino, or STL's that come from scanned data often have more problems.

Example of a file with many problems:

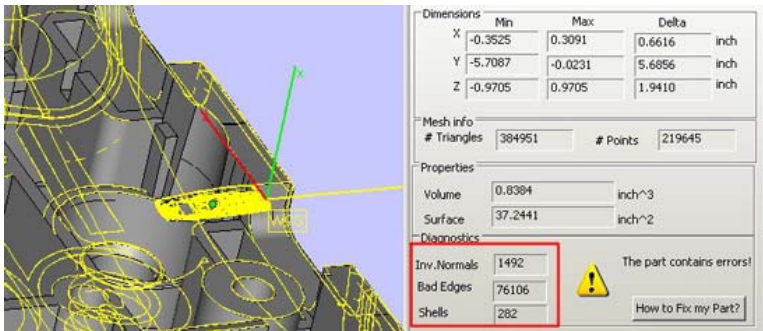

In the example above, the red highlighted area shows the major errors. And visually on the part, those areas are highlighted in yellow. Using a STL viewing tool, such as this one from Materialise.

You can easily find errors in your STL file by using a STL viewing tool. Unfortunately, most CAD programs do not allow you to view your final STL file, so you will likely have to install one separately. All viewing tools provide visual information, but some also provide you with visual information on where areas of concern are within your native file.

An example of a Rhino file created with surfaces that has been exported to STL is shown below.

Example of a Rhino file created with surfaces, then exported to STL:

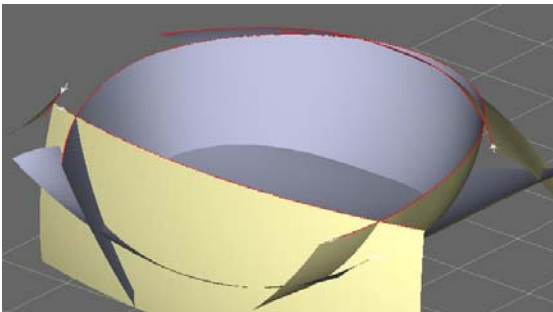

In the example above, the surfaces have not been trimmed correctly. Unfortunately, this means a service provider's slicing software will not be able to properly process this file leading to delays in production. After a file like this has been trimmed, it can be easily exported and uploaded to a local service provider.

## Conclusion

What you see can be exactly what you get. To get high quality prototypes to production parts the first time, make sure you check 7 key settings before file conversion: angle, deviation & chord height, wall thickness, surfaces, inversed normals and edges. To make your job even easier, you may also want to use a file viewer to catch areas of concern within your native file. In the end, your attention to detail will return a high quality part.

## About RedEye On Demand

RedEye On Demand is a service group of Stratasys that offers digital manufacturing services worldwide. The RedEye service center has access to more than 100 additive fabrication systems that produce rapid prototypes and low-volume production parts from engineering-grade thermoplastics. Users of the web-based service center can upload 3D CAD files and have their project delivered in days.

Online at: [www.RedEyeOnDemand.com](http://www.RedEyeOnDemand.com)